

1 Voltage Clamp

In order for a system to be voltage-clamped, the system must have the following properties. Given a voltage of the system V_s and a target voltage V_t the voltage clamp must provide a restoring current whenever V_s deviates from V_t . In other words, we must have a current I entering the system such that

$$I = g(V_t - V_s). \quad (1)$$

In this equation, we implicitly assume that g is a monotonic function of a real number x , passes zero at zero, and behaves as a high-gain amplifier. We propose one simple circuit which is capable of doing this.

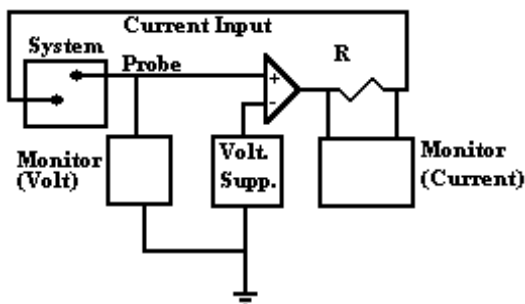

Figure 3. Voltage Clamp Setup

This circuit has the ability to monitor the current system voltage and the current influx to the system, making it useful in a number of experiments. It is similar to the original designs used by early investigators of neuroscience.

2 Current Clamp

In a current clamp experiment, we are interested in keeping the current into a system constant. However, the only measurements we are able to make are those of voltage. So, using the voltage measured across the system, we must be able to make a determination of the current entering the system.

Let us denote the system voltage by V_S and the current entering the system by I_S . Then we have the relation

$$V_S = \int I_S(t) dt. \quad (2)$$

Now, we would like to understand how we can measure this. In essence, we would like to have a differentiator. We can find such a device in an inductor. Let us see why. Consider the following figure:

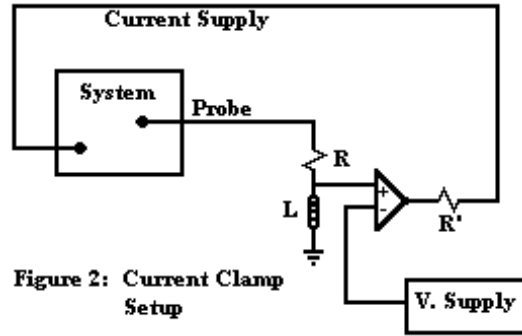

Figure 2: Current Clamp Setup

This is a simple current clamp. Let us determine the values for the required resistors and input voltage. We take the view that we can choose R and L , and are required to solve for R' . Clearly, the current through the inductance branch is given by

$$I_M = \frac{V_S}{R} \quad (3)$$

while the voltage across the inductor is given by

$$V_L = L \frac{dI_M}{dt} = \frac{L}{R} \frac{dV_S}{dt} = \frac{L}{R} I_S. \quad (4)$$

Now, if our objective is to provide a steady current of I_0 to the system, we need to reduce the amount of current by $I_S - I_0$. This may be accomplished if the amplification factor is $-\frac{R}{L}$, and the input voltage from the voltage supply is $\frac{L}{R} I_0$. In this case, the amplifier will respond by emitting a current of $I_0 - I_S$ as desired.